



Selection: Semi-hermetic Screw Compressors HS

Input Values

Compressor model	HSK7471-70	Operating mode	Standard
Refrigerant	R134a	Power supply	400V-3-50Hz
Reference temperature	Dew point temp.	Useful superheat	100%
Liq. subc. (in condenser)	0 K	Additional cooling	Automatic
Suct. gas superheat	10,00 K	Max. discharge gas temp.	80,0 °C

Result

Q [W]	Cooling capacity	mHP [kg/h]	Mass flow HP
P [kW]	Power input	Qac [kW]	Additional cooling
I [A]	Current	tcu [°C]	Liquid temp.
COP [-]	COP/EER	pm [bar(a)]	ECO pressure
mLP [kg/h]	Mass flow LP	Qsc [kW]	sub cooler capacity (ECO)

tc	to	10°C	5°C	0°C	-5°C	-10°C	-15°C	-20°C	-25°C
30°C	Q [W]	--	--	153554	125428	101484	81222	64181	--
	P [kW]	--	--	30,8	29,7	28,7	27,9	27,4	--
	I [A]	--	--	52,8	51,4	50,1	49,0	48,3	--
	COP [-]	--	--	4,99	4,23	3,54	2,91	2,34	--
	mLP [kg/h]	--	--	3345	2786	2301	1880	1518	--
	mHP [kg/h]	--	--	3345	2786	2301	1880	1518	--
	Qac [kW]	--	--	--	--	--	--	--	--
	tcu [°C]	--	--	30,0	30,0	30,0	30,0	30,0	--
	pm [bar(a)]	--	--	--	--	--	--	--	--
	Qsc [kW]	--	--	--	--	--	--	--	--
40°C	Q [W]	202035	167037	136978	111294	89470	71037	55569	--
	P [kW]	39,2	37,9	36,8	35,8	35,0	34,3	33,8	--
	I [A]	64,8	62,9	61,3	59,9	58,7	57,8	57,1	--
	COP [-]	5,15	4,40	3,72	3,11	2,56	2,07	1,64	--
	mLP [kg/h]	4641	3915	3278	2722	2237	1818	1456	--
	mHP [kg/h]	4641	3915	3278	2722	2237	1818	1456	--
	Qac [kW]	--	--	--	--	--	1,07	5,86	--
	tcu [°C]	40,0	40,0	40,0	40,0	40,0	40,0	40,0	--
	pm [bar(a)]	--	--	--	--	--	--	--	--
	Qsc [kW]	--	--	--	--	--	--	--	--
50°C	Q [W]	178256	146622	119514	96409	76831	60346	46561	--
	P [kW]	47,0	45,7	44,6	43,7	43,0	42,5	42,1	--
	I [A]	76,1	74,2	72,6	71,3	70,3	69,5	69,0	--
	COP [-]	3,79	3,21	2,68	2,20	1,79	1,42	1,10	--
	mLP [kg/h]	4539	3818	3185	2632	2150	1733	1373	--
	mHP [kg/h]	4539	3818	3185	2632	2150	1733	1373	--
	Qac [kW]	--	--	--	3,62	8,31	12,93	17,46	--
	tcu [°C]	50,0	50,0	50,0	50,0	50,0	50,0	50,0	--
	pm [bar(a)]	--	--	--	--	--	--	--	--
	Qsc [kW]	--	--	--	--	--	--	--	--

-- No calculation possible (see message in single point selection)

*According to EN12900 (10K suction gas superheat, 0K liquid subcooling)

Application Limits Standard

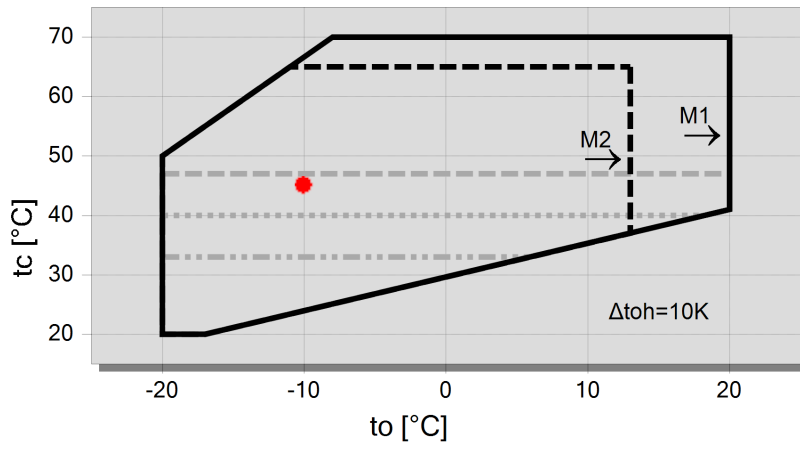

Legend

- max. tc for frequencies = 20Hz
- max. tc for frequencies = 25Hz
- max. tc for frequencies = 35Hz
- M1: motor 1
- - - M2: motor 2
- A



Technical Data: HSK7471-70

Dimensions and Connections

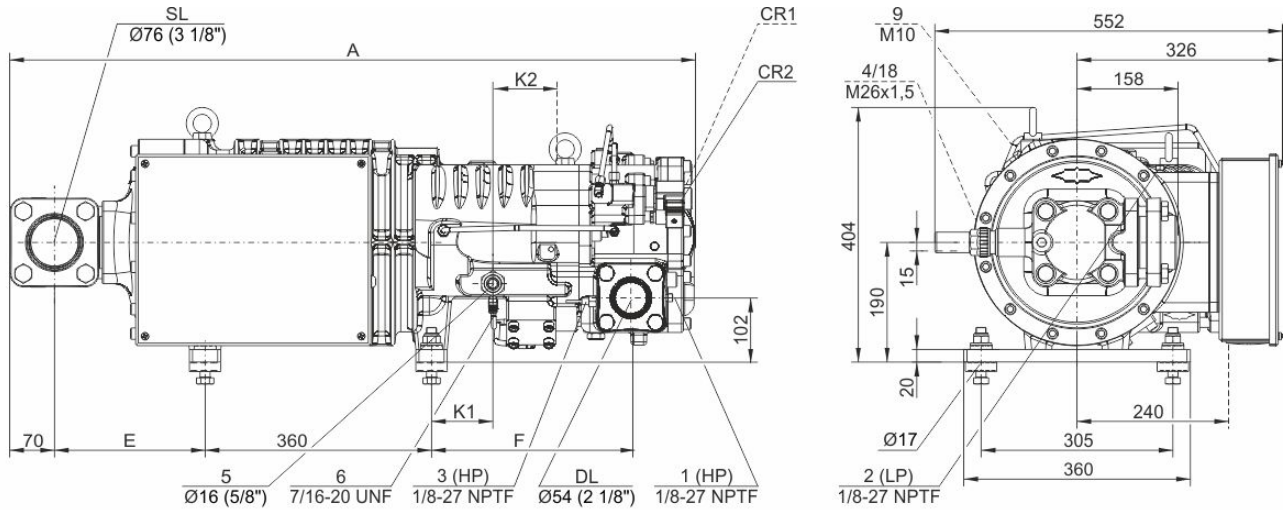

Model	A	E	F	K1	K2
	mm	mm	mm	mm	mm
HS.7451, HS.7461	1021	186	295	76	109
HSK7471-70, HSN7471-75	1034	186	318	98	97
HSK7471-90	1087	238	318	98	97

Technical Data

Technical Data

Displacement (2900 RPM 50 Hz)	250 m ³ /h
Displacement (3500 RPM 60 Hz)	302 m ³ /h
Weight	336 kg
Max. pressure (LP/HP)	19 / 28 bar
Connection suction line	76 mm - 3 1/8"
Connection discharge line	54 mm - 2 1/8"
Adapter/shut-off valve for ECO	22 mm - 7/8" (Option)
Adapter for liquid injection	16 mm - 5/8" (Option)
Oil type R22	B150SH, B100 (Option)
Oil type R134a/R404A/R507A/R407A/R407F	BSE170
Oil type R448A/R449A/R454C	BSE170

Motor data

Motor version	2
Motor voltage (more on request)	380-415V PW-3-50Hz
Max operating current	124.0 A
Starting current (Rotor locked)	290.0 A D / 485.0 A DD
Max. Power input	60,7 kW

Extent of delivery (Standard)

Discharge gas temperature sensor	Standard
Start unloading	Standard
Oil flow control	SE-B3 (Standard)
Motor protection	SE-E1 (Standard), SE-E3 (Standard for 660-690V)
Suction shut-off valve	Standard
Capacity control	100-75-50% (Standard)
Enclosure class	IP54

Available Options

Discharge shut-off valve	Option
ECO connection with shut-off valve	Option
Motor protection	SE-i1 (200-690V)



Sound measurement



Semi-hermetic Screw Compressors HS

HSK = Application for air-conditioning and medium temperature cooling.

HSN = Application for low temperature cooling.

Notes regarding application limits (see "Limits")

- * Ranges are valid for standard operation and at full-load conditions.
- * With high pressure conditions, part-load operation is partly limited (see application limits in applications manual SH-100).
- * With Economizer operation the maximum admissible evaporation temperature is shifted by 10K downward (otherwise there is a danger of excessive compression and overload of the motor because of a higher mass flow). At pull-down conditions from higher evaporation temperatures, the ECO injection must remain closed until the evaporation temperature is below the maximum admissible value and a stable operation is achieved (e.g. control of the ECO solenoid valve by means of a low pressure cut-out). The use of the ECO-system with higher evaporation temperatures requires individual consultation with Bitzer.

HS 64/74

- * Capacity control with ECO operation at the same time is limited to one single regulating step (CR 75%). At CR 50% the ECO injection should be closed.

Data for sound emission

Data are based on 50Hz application (IP-units 60Hz) and R404A.

Sound pressure level: values are based on open air test sites with semi-spherical sound emissions at 1 meter distance. For further information see Technical Information "Sound Data".

Legend of connection positions according to "Dimensions":

- 1 High pressure connection (HP)
Connection for high pressure switch (HP)
- 1a Additional high pressure connection (HP)
Not suitable for pressure switch or pressure transmitter!
- 1b Connection for high pressure transmitter (HP)
- 2 Low pressure connection (LP)
Connection for low pressure switch
- 2a Additional low pressure connection (LP)
- 2b Connection for low pressure transmitter (LP)
- 2c Low pressure connection for the minimum pressure differential control valve
- 3 Connection for discharge gas temperature sensor (HP)
- 4 Connection for economiser (ECO)
HS.85: ECO valve with connection line (option)
OS.85, OS.95, OS.105, HS.95: ECO valve (option)
- 5 Connection/valve for oil injection
- 6 Oil pressure connection
- 7 Oil drain (compressor or motor housing)
- 7a Oil drain (suction gas filter)
- 7b Oil drain from shaft seal (maintenance connection)
- 7c Oil drain hose (shaft seal)
- 8 Threaded bore for foot fastening
- 9 Threaded bore for pipe fixture (ECO and LI lines)
- 10 Maintenance connection for oil filter
- 11 Oil drain (oil filter)
- 13 Oil filter monitoring
- 14 Oil flow switch
- 15 Earth screw for housing
- 16 Pressure blow-off (oil filter chamber)
- 17 Maintenance connection for shaft seal
- 18 Liquid injection (LI)
- 19 Compressor module
- 20 Slider position indicator
- 21 Oil level switch
- 22 Oil pressure transmitter



- 23 Connection for oil and gas return (for systems with flooded evaporator adaptor optional)
- 24 Access to oil circulation restrictor
- 25 Oil inlet for shaft seal cooling
- 26 Oil outlet for shaft seal cooling
- 27 Temperature sensor in the shaft seal
- 28 Vibration sensor connection
- SL Suction gas line
- DL Discharge gas line

Dimensions can show tolerances according to EN ISO 13920-B.